

Product information sheet VICUS Twin lever

Item no. 526691

Benefits



- Classic design with modern functionality
- Satin Gold - easy to clean, stain and wear resistant
- High quality ceramic seals and cartridge for extremely long-lasting operation
- Available in different finishes

Colours

Available colours:
satin gold



PVD satin gold

Scope of supply

- Twin lever mixer tap
- WRAS approved fitting
- Classic design with modern functionality
- Suitable for low pressure gravity and pressure systems, max 5.0, min 0.3 bar
- Fit metal stabilising bracket if required, item No. 513383

Details

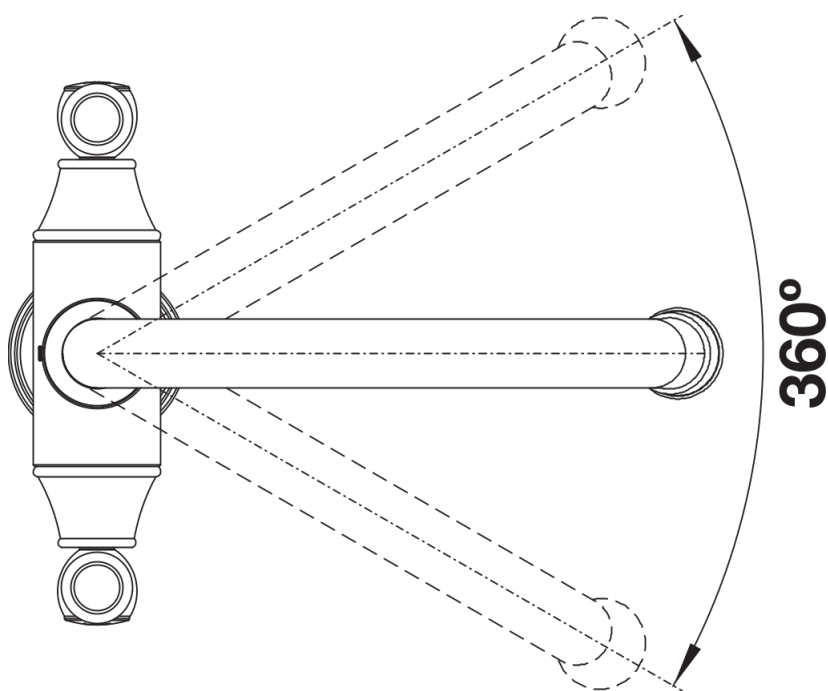

Swivel range

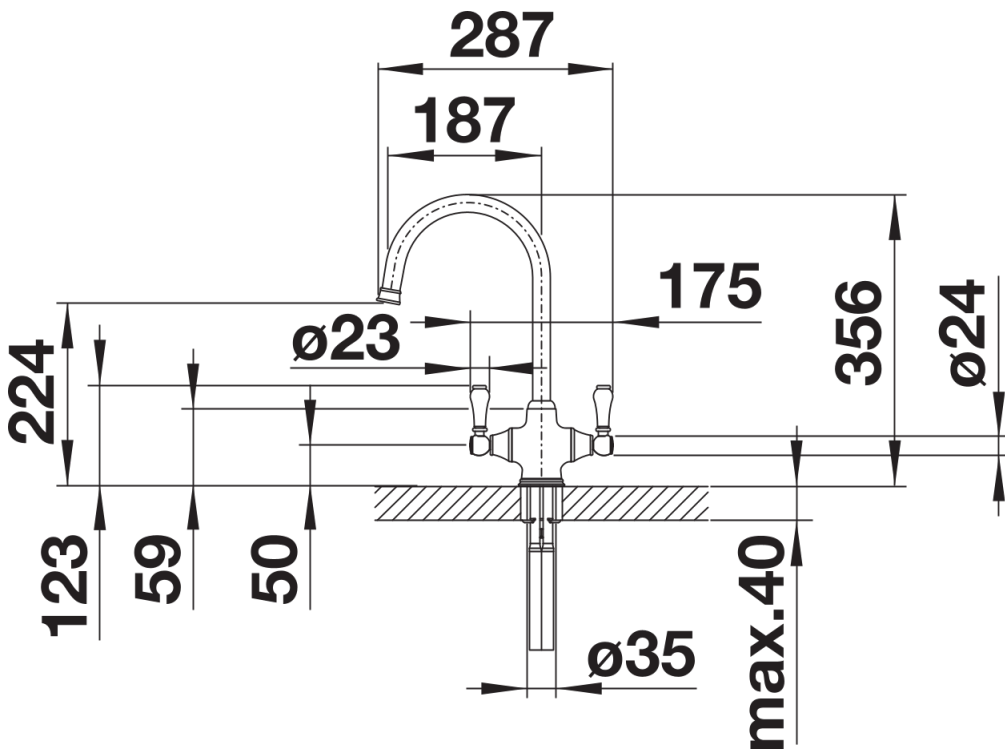
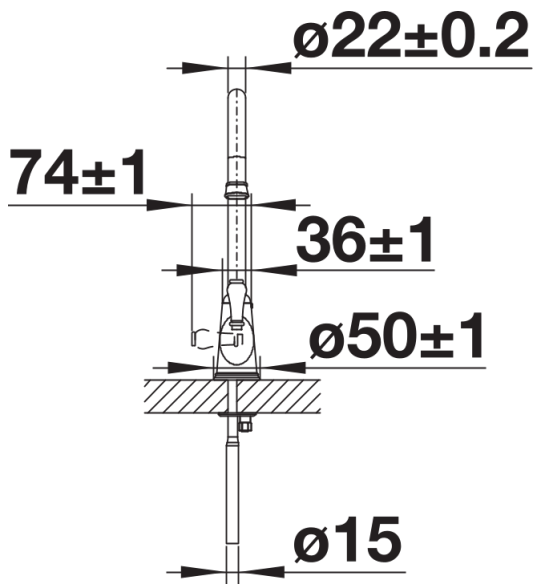

Side view